

FAST ALGORITHM FOR DETECTION OF NORMAL AND PATHOLOGICAL EVENTS IN LONG-PERIOD ELECTROCARDIOGRAM RECORDINGS

Stoyan Tanev¹, Plamen Trendafilov¹, Petar Genov¹, Lyudmila Taneva²

¹ Space Research Institute – Bulgarian Academy of Sciences

² Technical University – Sofia

e-mail: spsbyte@space.bas.bg

Abstract

Fast algorithm based on digital filters is considered. It is intended to detect normal and pathologic events in real ECG recordings. The methods for recognition of normal QRS complexes, pacemakers stimuli and supraventricular extrasystoles are described. The results of the data processing performed by a program based on the described algorithm are shown.

The processing of long-period ECG recordings requires relatively long time periods and depends on the used algorithms. On the other hand, it also depends on the microcontroller or PC computing power. The dedicated program products feature average processing time between 5 and 10 minutes after which, in many cases, manual data processing has to be done. As a result, the overall processing time grows up to one hour.

The aim of this work is to propose and describe a fast algorithm for detection of normal and pathologic events in a real 24-hour ECG recording where the average main processing time of the signal is reduced to 30 seconds. The great number of variations for the patterns of normal and pathological events makes the recognition process very difficult.

To solve the problem and satisfy the requirements arising from the nature of the ECG signal and processing time, digital filtration is chosen. The method of digital filtration is used as a base of the algorithm, where the output signal is given by equation (1):

$$(1) \quad Y[k] = \frac{1}{a_0} \left(\sum_{i=0}^m b_i x[k-i] - \sum_{j=1}^n a_j [k-j] \right)$$

Where: $x[k]$ - input data and a_j, b_i - constant coefficients.

To reveal the specific parts in the ECG recording, it is expedient to use a digital filter with second order Butterworth type infinite pulse characteristic, whose structure is shown in Fig.1.

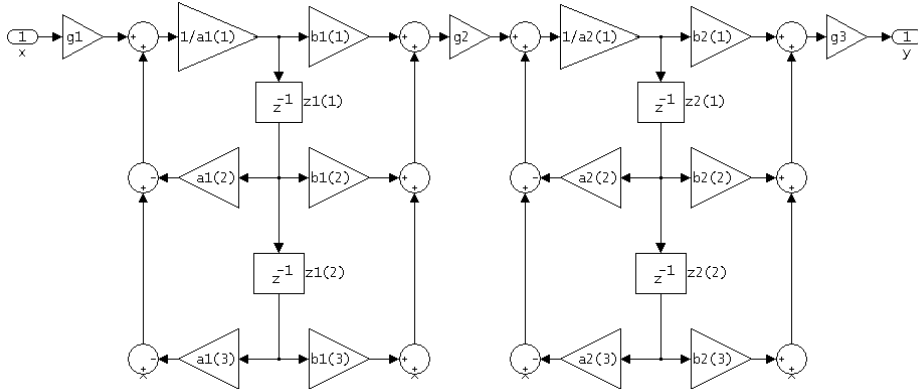

Fig. 1. Structure of the used Butterworth type digital filter

Where: X – filter input;
 Y – filter output;
 $g1, g2, g3$ – gain coefficients;
 $a(1,2,3) b(1,2,3)$ – filter coefficients;
 $z^{-1}(1,2,3)$ – the last value of Z ;

The signal processed with this filter provides to obtain the required filter slope and high event-detection speed typical for the ECG signal. The algorithm of the signal processing is shown in Fig. 2.

The algorithm works with two data arrays, $Buff1[n]$ and $Buff2[n]$, registered by the first and second channel of the ECG holder. The length of the record is 24 hours. The $Event[n]$ array is intended to save the type and place of the discovered event. N_k is a constant representing the number of discrete determined by formula (2).

$$(2) \quad N_k = \frac{120 * F_d}{1000}$$

Where: Nk discrete number, 120 constant (set equal to 120 ms and used as time threshold in detecting ventricular extrasystoles)

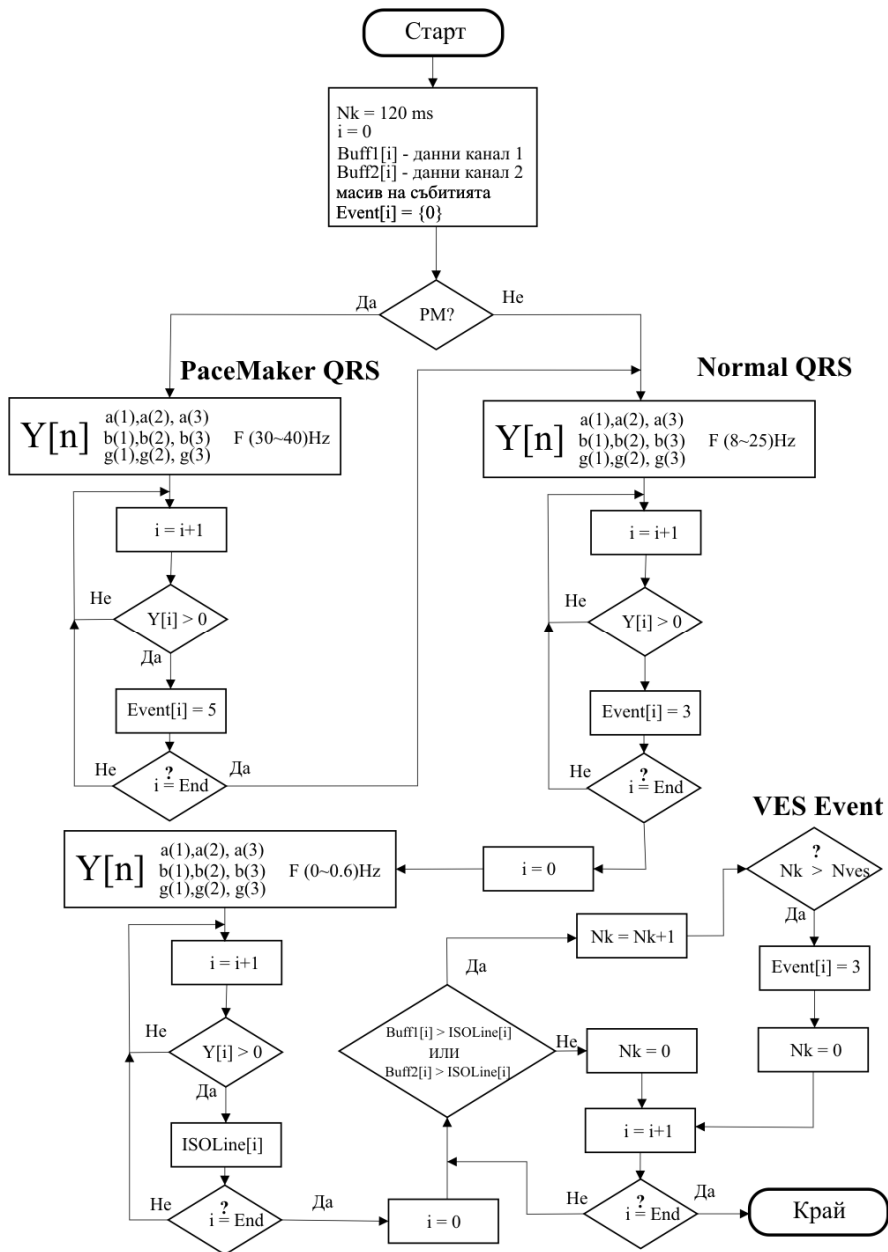

Fig. 2. Signal processing algorithm

In practice, quite often, ECG data recorded by different types of pacemakers, such as unipolar, bipolar, “on demand” and more has to be processed. This makes data processing more difficult. A common feature of all these devices is the generation of a short pulse (width of 1-7 ms) with each heart contraction.



Fig. 3. Determination of the stimulating pulse place in the RR interval

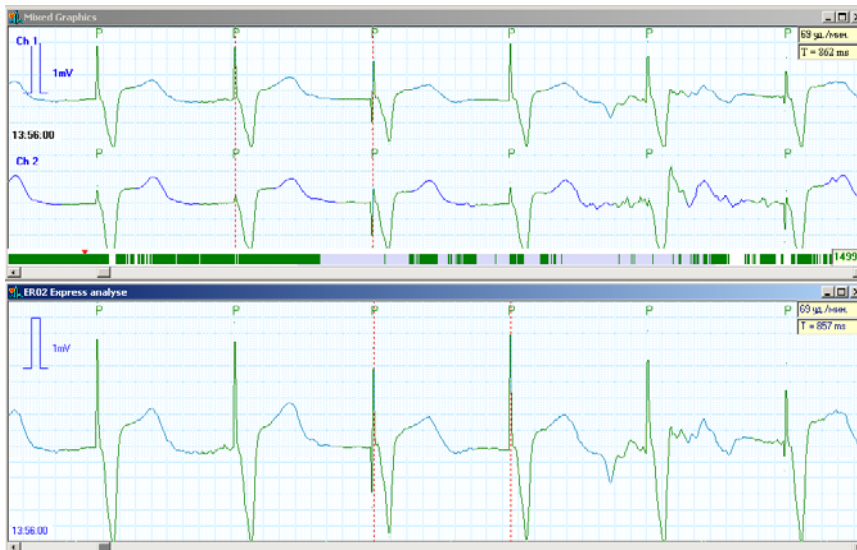

Fig. 4. Results after the signal processing

To find the place of the stimulation pulse in the RR interval, the signal has to be passed through a band digital filter with band frequencies of 20-30 Hz. If the signal is greater than the preliminary set threshold (not shown in Fig. 2 to simplify the algorithm's diagram), we consider that a stimulation pulse is generated at this place. Then, all signals greater than the threshold are ignored for a time period equal to 200 ms corresponding to heart rate of 300 beats per minute, upon detecting the event (Fig. 3). The results of the signal processing are shown in Fig. 4.

If there is no indication of the presence of cardiostimulator, the algorithm starts processing the signal using the band pass filter within the range of 12-20 Hz. The difference between the levels in the same part of the recording, processed by a detecting filter for stimulator generated pulses and the normal QRS complex is shown in Fig. 5 (20-30 Hz) and Fig. 6 (12-20 Hz).

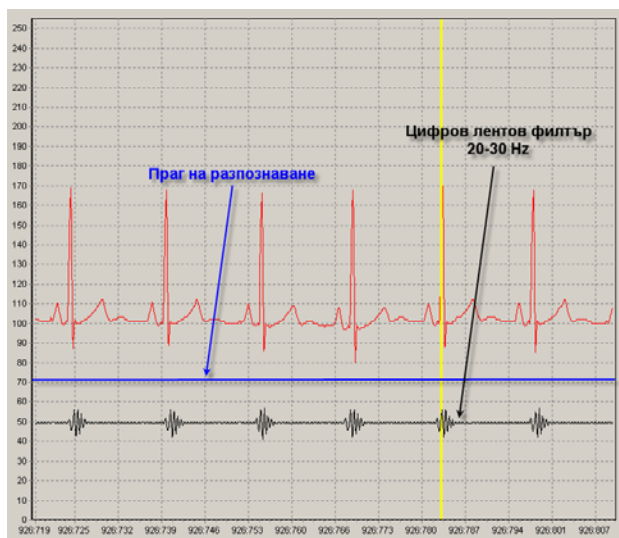

Fig. 5. Detecting pulses generated by a cardiostimulator

During the analysis and detection of the normal QRS complexes, time-frequency valuation could be applied, using the proposed algorithm for VES detection. Ventricular extrasystoles (VES) are wider than normal QRS complexes. Normal QRS complexes change within the range of 50–110 ms for healthy people and depend on sex and age. For VES detection, the signal must be processed using a low pass digital filter with frequency of 0–0.7 Hz.

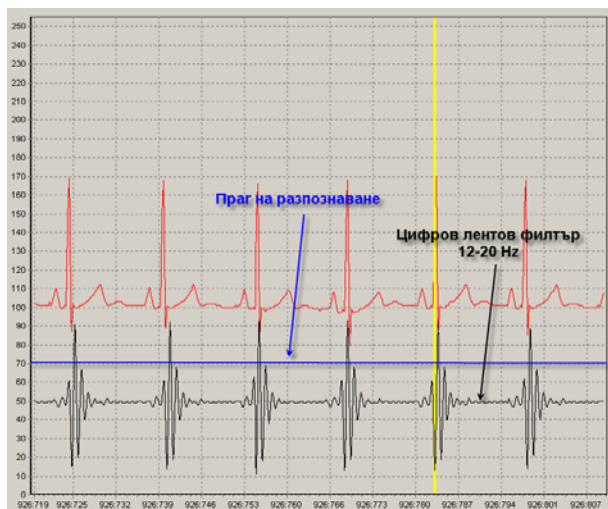

Fig. 6. Detecting pulses from normal QRS complex

The output of the filter follows the isoline of the signal recorded by the registration device and is used as start voltage threshold – first crossing point of the event on the graphic and the filter output signal, or end voltage threshold – second crossing point of the event on the graphic and the filter output signal. If the measured time is greater than 120 ms, the algorithm determines that a VES event is discovered. The measurement is presented in Fig. 7.

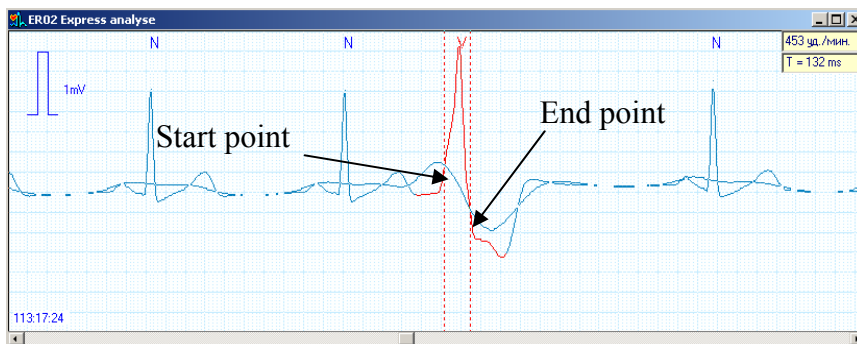

Fig. 7. VES detection algorithm

The signal processing is carried out simultaneously on both channels. It is enough to satisfy the requirement for the time threshold in one of the two channels to determine that the event is VES. The presence of

artifacts with width close to VES's width will be recognized as a VES. The correction can be made by secondary data analysis and the application of various correlation analyses.

Conclusion

The method described above reduces greatly the time period of long time period ECG recordings. The method increases the reliability of the data processing results. The fast algorithm provides to make one or more processing passes of the signal for secondary analysis. Analyses for different recording lengths are possible. The method is useful in cases where human status needs to be determined quickly under extreme conditions, such as during space missions.

References

1. P a n J. and T o m p k i n s W. J. (1985): 'A real-time QRS detection algorithm', *Eng.*, 33, pp. 1157–1165.
2. M e r v i n J. G. and G o l d s c h a l a g e r N. (1989): 'Principles of clinical Electrocardiography', *Appleton Lange*.
3. F r i e s e n G. M., C. J. T h o m a s, M. A. J a d a l l a h, S. L. Y a t e s, S. R. Q u i n t, and H. T. N a g l e (1990): 'A comparison of noise sensitivity of 9 QRS detection algorithms', *IEEE Trans. Biomed. Eng.*, 37(1), pp. 85–98.
4. L i n P. K. and C h a n g W. H. (1997): 'A technique for automated arrhythmia detection of holter ECG', *In Proceedings of Engineering in Medicine and Biology*, 35, pp. 626–631.

БЪРЗ АЛГОРИТЪМ ЗА ОТКРИВАНЕ НА НОРМАЛНИ И ПАТОЛОГИЧНИ СЪБИТИЯ В ЕЛЕКТРОКАРДИОГРАФСКИ ЗАПИСИ С ГОЛЯМА ПРОДЪЛЖИТЕЛНОСТ

Ст. Танев, Пл. Трендафилов, П. Генов, Л. Танева

Резюме

Разгледан е бърз алгоритъм за откриване на нормални и патологични събития в реален ЕКГ запис. Алгоритъмът е базиран на обработка на сигнала с цифров филтър от втори ред тип Butterworth.

Описани са етапите при обработката на сигнала за разпознаване на нормални QRS комплекси, стимулиращи импулси от кардиостимулатор и камерни екстрасистоли. Постигната е висока скорост на бързодействие и висока степен на достоверност на резултатите при използване на минимални изчислителни ресурси. Показани са резултатите от анализа на сигнала с програма, работеща по описания алгоритъм.